

1. NOTES ON MPPT (Maximum Power Point Tracker)

Solar irradiation on a surface such as the surface of a photovoltaic system has extremely variable characteristics, since it depends on the position of the sun with respect to the surface and on atmospheric conditions (typically, on the presence of clouds). A photovoltaic module presents, for different solar irradiation values, and for different temperature values, a range of characteristic curves of the type shown in the following figure. In particular, the figure shows three I-V curves (in bold) which correspond to three values (1000, 800, 600W/m²) of solar irradiation

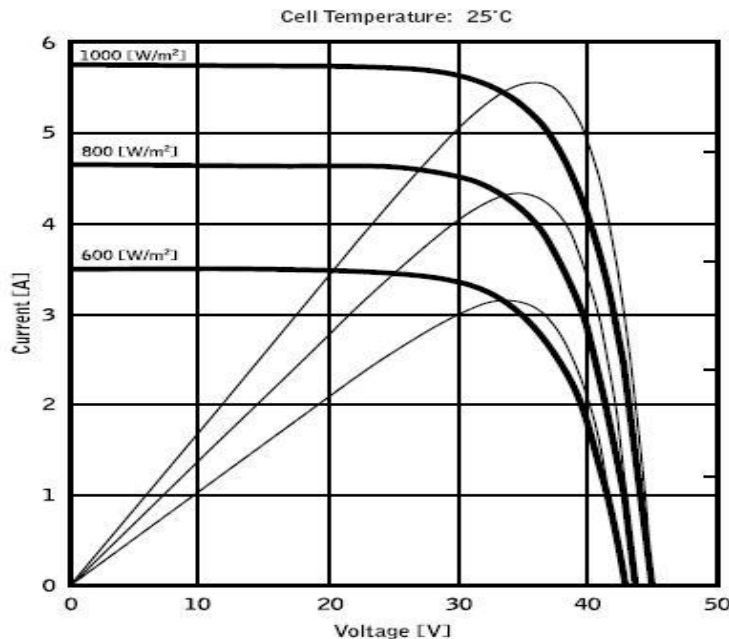

On each characteristic curve there is one single point in which the power transfer towards a hypothetical charge supplied by the photovoltaic module is maximized. The maximum power point corresponds to the voltage-current pair for which the product $V \cdot I$ is maximum, where V is the value of voltage at the module's terminals and I is the current which runs in the circuit obtained by closing the module on a hypothetical charge.

With reference to the figure above, the product $V \cdot I$ is represented, for the three solar irradiation values mentioned above, through the three curves in thinner lines. The figure shows that, as stated above, these curves only have one single maximum point. For example, for 1000W/m², the maximum power point corresponds to a voltage value of approx. 36V and to a current value of approx. 5.5A.

Obviously, if the power provided by the system is maximized, it is possible to make the most of the system, both in case the system is connected to mains, and in case it is stand-alone.

MPPT is an inbuilt device in the inverters. It typically reads the voltage and current values at any instant, calculates their product (i.e. the power in Watts) and, by causing small variations in the conversion parameters (duty cycle), it is capable of determining, by comparison, if the photovoltaic module is working in maximum power conditions or not. According to the result, it operates again on the circuit in order to bring the system to an optimal condition. **The reason why MPPTs are used is simple: a photovoltaic system without MPPTs may operate anyway. However, with the same solar irradiation, it provides less energy.**

There are inverters with 1, 2 or also 3 inbuilt MPPTs available on the market. Typically, the inverters with more than one MPPT are used in systems where:

- The different photovoltaic systems it consists of "forcibly" have different inclinations or directions. In this way, each single MPPT manages its own photovoltaic field, maximizing its performance for the corresponding irradiation and temperature characteristics (without being influenced by the other photovoltaic fields)
- A greater service continuity is sought. With more MPPTs it is possible to put one single photovoltaic field out of service, while the others continue producing energy towards the remaining MPPTs.

2. DESCRIPTION OF MPP300 ACCESSORY

The **MPP300** model has been designed as an exclusive accessory of a Master **SOLAR300N** and **SOLAR I-V** instruments for the purpose of carrying out testing simultaneous operations on single-phase and three-phase PV systems with up to 3 Multi MPPT device

Together with a Master instrument (see enclosed principle scheme) MPP300 is the ideal solution for testing and analyzing the possible problems linked to possible low efficiency values of photovoltaic systems

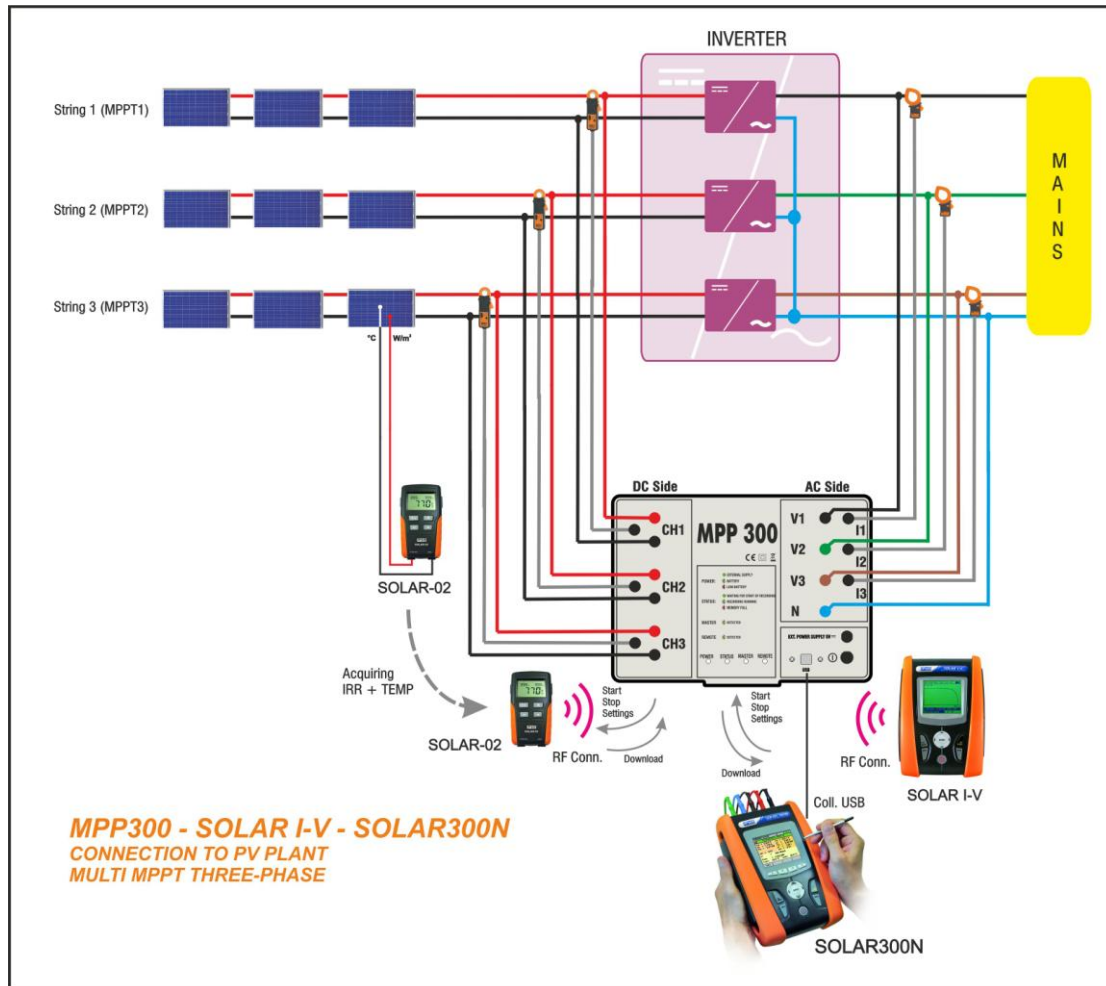

The instrument has the following features:

Testing of PV systems with single/multi-MPPT inverter - single/three-phase AC output

- Using with Master instruments SOLAR300N and SOLAR I-V
- Measurement of 3 DC voltages and currents
- Measurement of DC string power and total DC power
- Measurement of 3 AC TRMS voltages and currents
- Measurement of total AC power
- Measurement of irradiation [W/m^2] by means of a reference cell connected to unit SOLAR-02
- Measurement of panel and environmental temperature by means of probe PT300N connected to SOLAR-02
- Parameter recording of a PV system with 5s to 60min programmable IP
- Operations with LED indication
- Internal memory for data saving
- RF interface for transferring the data to the SOLAR I-V instrument and SOLAR-02 remote unit
- USB interface for transferring the data to the SOLAR300N instrument



3. TECHNICAL SPECIFICATIONS (*)

Accuracy is indicated as [%reading + (no. of digits) * resolution] at 23°C ± 5°C, <80%HR

DC Voltage

Range (V)	Resolution (V)	Accuracy
10.0 ÷ 999.9	0.1	± (0.5%rdg + 2dgt)

AC TRMS Voltage – Phase-Neutral – Single/Three phase systems

Range (V)	Frequency (Hz)	Resolution (V)	Accuracy
10.0 ÷ 346.0	42.5 ÷ 69.0	0.1	± (0.5%rdg + 2cifre)

Max. crest factor: 1.5

AC TRMS Voltage – Phase-Phase

Range (V)	Frequency (Hz)	Resolution (V)	Accuracy
50.0 ÷ 594.0	42.5 ÷ 69.0	0.1	± (0.7%rdg + 2dgt)

Max. crest factor: 1.5

DC Current by means of external clamp transducer STD type

Range (mV)	Resolution (mV)	Accuracy	Overload protection
5.0mV ÷ 319.9mV	0.1mV	± (0.5%rdg + 0.06%FS)	10V
320.0mV ÷ 999.9mV		± 0.5%rdg	

Current values corresponding to a voltage < 5mV are zeroed

AC TRMS Current by means of external clamp transducer STD type

Range (mV)	Frequency (Hz)	Resolution (mV)	Accuracy	Overload protection
5.0mV ÷ 219.9mV	42.5 ÷ 69.0	0.1mV	± (0.5%rdg + 0.06%FS)	10V
220.0mV ÷ 999.9mV			± 0.5%rdg	

Max. crest factor: 1.5 ; Current values corresponding to a voltage < 5mV are zeroed

AC TRMS current (by means of external clamp transducer of FLEX 8.5µV/A – FS 100A)

Range (mV)	Frequency (Hz)	Resolution (mV)	Accuracy	Overload protection
0.008 ÷ 8.50mV	42.5 ÷ 69.0Hz	0.001mV	± (0.5%rdg + 7dgt)	10V

Max. crest factor: 1.5 ; Current values < 1A are zeroed

AC TRMS current (by means of external clamp transducer of FLEX 8.5µV/A – FS 1000A)

Range (mV)	Frequency (Hz)	Resolution (mV)	Accuracy	Overload protection
0.085 ÷ 85.0mV	42.5 ÷ 69.0Hz	0.01mV	± (0.5%rdg + 15dgt)	10V

Max. crest factor: 1.5 ; Current values < 5A are zeroed

DC Power (V_{mis} > 150V)

Parameter	FS clamp (A)	Range [W]	Resolution [W]	Accuracy
DC POWER	1 < FS ≤ 10	0.000k ÷ 9.999k 10.00k ÷ 99.99k	0.001k 0,01k	± (0.7%rdg+3dgt) (Imis < 10%FS)
	10 < FS ≤ 100	0.00 ÷ 99.99k 100.0k ÷ 999.9k	0.01k 0.1k	
	100 < FS ≤ 1000	0.0k ÷ 999.9k 1000k ÷ 9999k	0.1k 1k	± (0.7%rdg) (Imis ≥ 10%FS)

V_{mis} = voltage at which power is measured; Imis = measured current

**AC Power ($V_{mis} > 200V$, $PF=1$)**

Parameter	FS clamp (A)	Range [W]	Resolution [W]	Accuracy
AC POWER	$1 < FS \leq 10$	0.000k ÷ 9.999k 10.00k ÷ 99.99k	0.001k 0,01k	$\pm (0.7\%rdg+3dgt)$ ($I_{mis} < 10\%FS$)
	$10 < FS \leq 200$	0.00 ÷ 99.99k 100.0k ÷ 999.9k	0.01k 0.1k	
	$200 < FS \leq 1000$	0.0k ÷ 999.9k 1000k ÷ 9999k	0.1k 1k	$\pm (0.7\%rdg)$ ($I_{mis} \geq 10\%FS$)

V_{mis} = voltage at which power is measured; I_{mis} = measured current

4. GENERAL SPECIFICATIONS**POWER SUPPLY:**

Internal power supply: Internal rechargeable Li-ION battery (3.7V, 1900mAh)
Battery duration: > 3 hours
External power supply: AC/DC adapter 100-240V 50/60Hz / 5VDC

CHARACTERISTICS OF RADIO MODULE

Frequency range: 2.400 ÷ 2.4835GHz
R&TTE category: Class 1
Max transmission power: 30μW
Max RF connection distance: 1m

MEMORY AND EXTERNAL INTERFACE

Memory capacity: 2Mbytes
Integration Period (IP): 5,10,30,60,120,300,600,900,1800,3600s
RF interface: connection SOLAR I-V and SOLAR-02 units
USB interface: connection SOLAR300N unit
Battery duration (with SOLAR-02): approx. 1.5 hours (@ PI = 5s) ; approx. 8 days (@ PI = 600s)

MECHANICAL CHARACTERISTICS

Dimensions (LxWxH): 300 x 265 x 140 mm
Weight (battery included): 1.2 kg
Protection index: IP40

ENVIRONMENTAL CONDITION FOR USE

Reference temperature: 23°C ± 5°C
Operating temperature: 0° ÷ 40°C
Allowable relative humidity: <80%hr
Storage temperature: -10 ÷ 60°C
Storage humidity: <80%HR

REFERENCE STANDARDS

Safety: IEC/EN61010-1
Safety of measuring accessories: IEC / EN61010-031
Insulation: double insulation
Pollution level: 2
Measurement category: CAT III 1000V DC, Max 1000V between DC inputs
CAT IV 300V AC to ground, Max 600V between AC inputs
Max operating altitude: 2000m

This instrument satisfies the requirements of Low Voltage Directive 2006/95/EC (LVD) and of EMC Directive 2004/108/EC

(*) *Technical specifications can be modified without preliminary advise*

Diensten van EURO-INDEX

EURO-INDEX is fabrikant, importeur en distributeur van diverse A-merken op het gebied van test- en meetinstrumenten. Daarnaast leveren wij een groot aantal diensten om het gebruik van deze instrumenten in uw bedrijfsvoering te optimaliseren. Dit omvat uiteraard onderhoud, reparatie en kalibratie van de instrumenten, maar ook kennisdeling via de EURO-INDEX Academy en verhuur van instrumenten.

Geautoriseerd Service Centrum

EURO-INDEX b.v. is van alle vertegenwoordigde merken een Geautoriseerd Service Centrum. Dit betekent dat uw instrumenten worden behandeld door technici die zijn opgeleid door de fabrikant en beschikken over de juiste gereedschappen en software. Er worden uitsluitend originele onderdelen toegepast en de garantie van uw instrument, evenals de certificering (ATEX, EN50379, etc.) blijven intact.

Kalibratielaboratorium

Ons moderne service- en kalibratielaboratorium beschikt over een RvA accreditatie naar NEN-EN-ISO/IEC 17025. Deze accreditatie geldt voor grootheden, zoals gespecificeerd in de scope bij accreditatienummer K105.



Kijk voor een overzicht van al onze diensten op euro-index.nl/diensten



Mobiele Service

Naast de vaste kalibratielaboratoria in Capelle aan den IJssel en Zaventem beschikken wij ook over een laboratorium op wielen met de naam "Mobiele Service". Dit biedt vertrouwde service en kwaliteit, bij u voor de deur!

KWS®

KWS® is een uniek servicesysteem voor uw meetinstrumenten met periodiek onderhoud en kalibratie tegen vaste, lage kosten. Via een gratis webportal (mijnkws.nl) heeft u altijd en overal beschikking over uw kalibratiecertificaten.

Verhuur van meetinstrumenten

- Uitgebreid assortiment
- Nauwkeurigheid aantoonbaar door actueel kalibratiecertificaat
- Deskundig advies
- Complete levering inclusief accessoires

EURO-INDEX Academy

- Trainingen (individueel en klassikaal)
- Cursussen en workshops
- Demonstratie- en instructievideo's
- Whitepapers



Servicebalie



Onderhoud, reparatie en kalibratie



Cursussen en workshops



Mobiele Service

Wijzigingen voorbehouden EURO-INDEX® NL 21004



NETHERLAND
Rivium 2e straat 12
2909 LG Capelle a/d IJssel
T: 010 - 2 888 000
F: 010 - 2 888 010
verkoop@euro-index.nl
www.euro-index.nl



BELGIË
Leuvensesteenweg 607
1930 Zaventem
T: +32 - (0)2 - 757 92 44
F: +32 - (0)2 - 757 92 64
info@euro-index.be
www.euro-index.be